

SENSIA EX

Multi-Way Reach Truck • AC Power
2.0 – 2.5 tonnes

The wide load specialist... with narrow aisle agility

The Mitsubishi SENSIA EX multi-way reach truck range is ideal for precise and intuitive handling of wide and unusual loads of up to 2500 kg - and lifting up to 10 metres - in narrow aisles and on long shifts.

Six multi-directional travel modes, all-wheel steering and braking and powerful AC traction combine to deliver exceptionally agile, high-intensity performance. Its wide forks make long handling exact and effortless.

Comfortable and spacious, the award-winning SENSIA cabin, SDS and operator controls provides excellent all-round visibility and minimises operator fatigue.

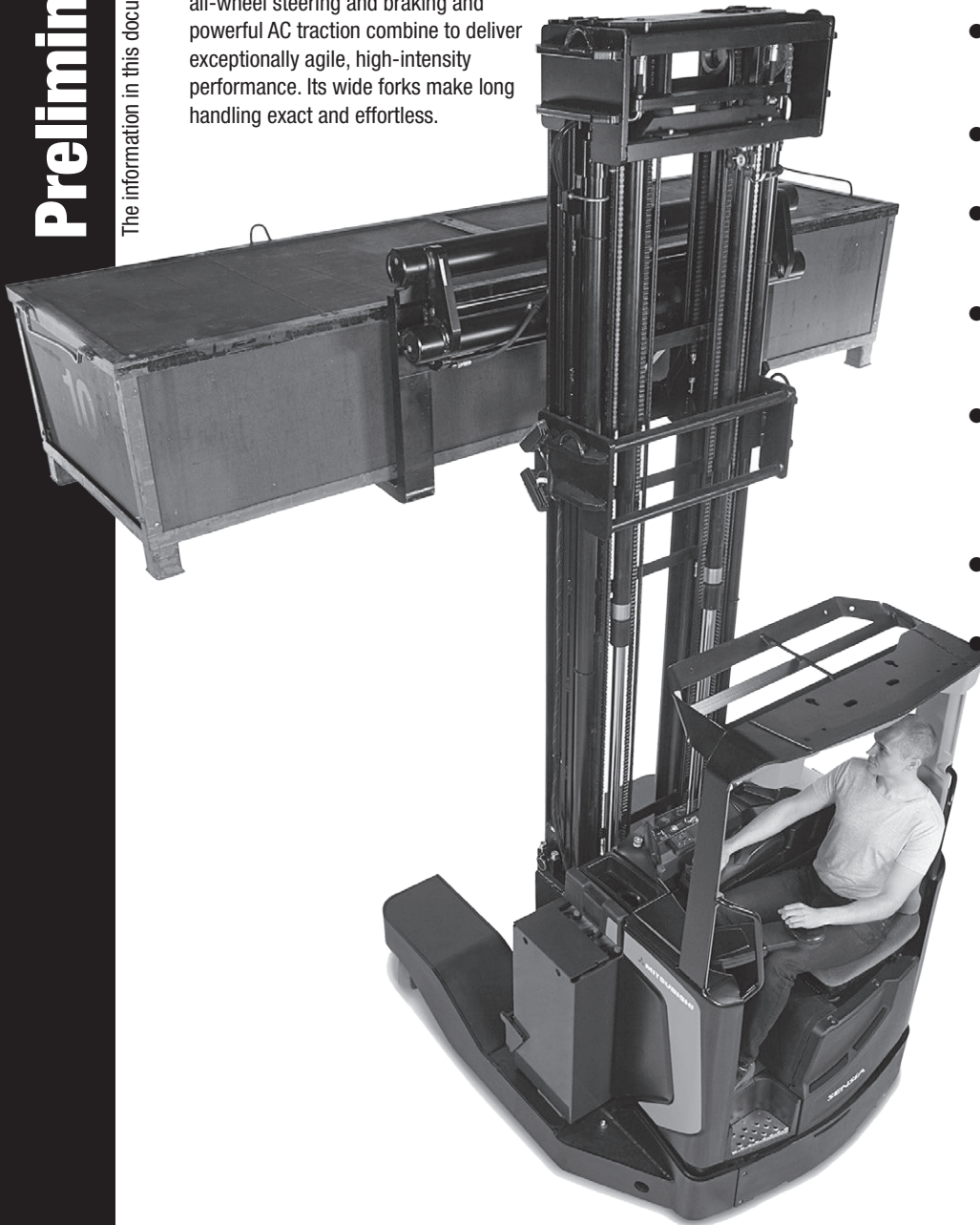

Frame and body

- **Choice of 2000kg and 2500kg models** for optimum application configuration.

Mast and fork assembly

- **Smooth mast handling system on lift and reach** for steady, predictable and precise handling.
- **Wide fork positioner with up to 2200mm spread and fork tilt** for handling both long loads and standard pallets.
- **Passive Sway Control** dampens any elevated load motion by allowing the chassis to move slightly to compensate.
- **Lift heights up to 10 metres** for higher handling.

Drive

- **Six multiway driving modes, instantly selected by keypad** – reach truck, lateral, parallel, auto-transition, rotational and agile cornering.
- **Mitsubishi SDS (Sensitive Drive System)** provides intuitive driver-assist with graduated performance management according to steer angle, foot and finger actuator velocity - significantly contributing to safety.
- **Next-generation 360° load wheels** with independently controlled steer motors.
- **Load wheels turn within chassis leg profile** for added protection of wheels and loads.

SENSIA EX

Multi-Way Reach Truck • AC Power

2.0 – 2.5 tonnes

Characteristics					
1.1	Manufacturer			Mitsubishi	Mitsubishi
1.2	Manufacturer's model designation			RBM20N2	RBM25N2
1.3	Power source: (battery, diesel, LP gas, petrol)			Battery	Battery
1.4	Operator type: pedestrian, (operator)-standing, -seated			Seated	Seated
1.5	Load capacity	Q	(kg)	2000	2500
1.6	Load center distance	c	(mm)	600	600
1.8	Load wheel axle to fork face (forks lowered)	x	(mm)	337	337
1.9	Wheelbase	y	(mm)	1552	1552
Weight					
2.1	Truck weight with load, with maximum battery weight		kg	6888*	7784**
2.3	Axle loadings without load & with maximum battery weight, drive/load side		kg	2672 / 2 x 1108*	2907 / 2 x 1188**
2.4	Axle loading, mast forward, with nominal load, drive/load side		kg	591 / 2 x 3148*	521 / 2 x 3631**
2.5	Axle loading, mast retracted, with nominal load, drive/load side		kg	2292 / 2 x 2298*	2292 / 2 x 2298**
Tyres					
3.1	Tyres: PT=Power Thane, Vul=Vulkollan, drive / load side			Vul	Vul
3.2	Tyre dimensions, drive side		(mm)	Ø360 x 140	Ø360 x 140
3.3	Tyre dimensions, load side		(mm)	Ø285 x 75 x 2	Ø285 x 75 x 2
3.5	Number of wheels, load / drive side, (x=driven)			2+2/1x	2+2/1x
3.7	Track width (center of tyres), load side	b11	(mm)	1384	1384
Dimensions					
4.1	Fork tilt, forwards / backwards	α/β	°	2.0 / 6.0	2.0 / 6.0
4.2	Height with mast lowered	h1	(mm)	see table	see table
4.3	Free lift	h2	(mm)	see table	see table
4.4	Lift height	h3	(mm)	see table	see table
4.5	Height, mast extended	h4	(mm)	see table	see table
4.7	Height to top of overhead guard	h6	(mm)	2190	2190
4.8	Seat- or stand height	h7	(mm)	1030	1030
4.10	Height of support legs	h8	(mm)	447	447
4.15	Fork height, fully lowered	h13	(mm)	50	50
4.19	Overall length	l1	(mm)	2630	2630
4.20	Length to fork face	l2	(mm)	1480	1480
4.21	Overall width	b1/b2	(mm)	1730	1730
4.22	Fork dimensions (thickness, width, length)	s / e / l	(mm)	50 / 120 / 1150	50 / 120 / 1150
4.24	Fork carriage width	b3	(mm)	1700 / 2200	1700 / 2200
4.25	Outside width over forks (minimum/maximum)	b5	(mm)	500-1700 / 2200	500-1700 / 2200
4.26	Innerwidth of the support legs	b4	(mm)	900	900
4.28	Mast reach	l4	(mm)	610	610
4.32	Ground clearance at center of wheelbase, (forks lowered)	m2	(mm)	75	75
4.33/a	Working aisle width (Ast) with 1000 x 1200 mm pallets, load crosswise	Ast	(mm)	2887	2887
4.34/b	Working aisle width (Ast3) with 800 x 1200 mm pallets, load lengthwise	Ast3	(mm)	2850	2850
4.35	Turning radius	Wa	(mm)	1787	1787
4.37	Truck length including support legs	l7	(mm)	1982	1982
Performance					
5.1	Travel speed, with / without load		km/h	14 / 14	14 / 14
5.2	Lifting speed, with / without load		m/s	0.43 / 0.58	0.39 / 0.58
5.3	Lowering speed, with / without load		m/s	0.50 / 0.55	0.50 / 0.55
5.4	Reach speed, with / without load		m/s	0.1 / 0.1	0.1 / 0.1
5.8	Maximum gradeability, with / without load		%	11.0 / 17.0	11.0 / 17.0
5.9	Acceleration time (10 metres) with / without load		s	5.4 / 5.0	5.6 / 5.1
5.10	Service brake			Mechanical	Mechanical
Electric motors					
6.1	Drive motor capacity (S2 60 min. short duty)		kW	7.5	7.5
6.2	Lift motor output at S3 15% duty factor		kW	14	14
6.4	Battery voltage/capacity at 5-hour discharge		V/Ah	48 / 775, 930	48 / 775, 930
6.5	Battery weight		kg	1100, 1300	1100, 1300
6.6	Energy consumption according to EN 16796 cycle***		kWh/h	4.5	4.5
Miscellaneous					
8.1	Type of drive control			Stepless	Stepless
10.7****	Level of noise at ear level of the driver according to EN ISO 4871 in work LpAZ		dB(A)	68	68
10.7.1****	Level of noise at ear level of the driver according to EN ISO 487, drive/lift/idle LpAZ		dB(A)	80	80
Body	Whole-body vibration (EN 13 059:2002)		m/s ²	0.5	0.5
Hand	Hand-arm vibration (EN 13 059:2002)		m/s ²	<2.5	<2.5

* Weight values measured with 5700mm lift height mast & 775Ah battery

** Weight values measured with 10000mm lift height mast & 930Ah battery

*** Energy consumption values measured with 5700mm lift height mast

**** Inaccuracy of 4dB (A)

Continuing improvement may lead to changes in these specifications.

Model	Battery Capacity	Battery Weight	4.33 (1000 x 1200mm crosswise) Ast	4.34 (800 x 1200mm lengthwise) Ast3	L4	L2	L1	x
RBM20N2 & RBM25N2	Ah	kg	mm	mm	mm	mm	mm	mm
	775	1100	2887	2850	610	1480	2630	337
	930	1300	2887	2850	610	1480	2630	337

RBM20N2 / RBM25N2				
Mast Type	h1	h2	h3	h4
	mm	mm	mm	mm
TREV	2510	1800	5400	6200
	2610	1900	5700	6500
	2677	1967	5900	6700
	2810	2100	6300	7100
	3043	2333	7000	7800
	3210	2500	7500	8300
	3377	2666	8000	8800
	3543	2833	8500	9300
	3710	3000	9000	9800
	3877	3167	9500	10300
	4043	3334	10000*	10800

Ast = $Wa + \sqrt{(l6 - x)^2 + (b12/2)^2} + a$
 Ast3 = $Wa + l6 - x + a$
 l6 = Pallet length (1200 mm)
 b12 = Pallet width (800 or 1200 mm)
 a = Safety clearance = 2 x 100 mm
 TREV = Triplex with free lift

* only available for RBM25N2

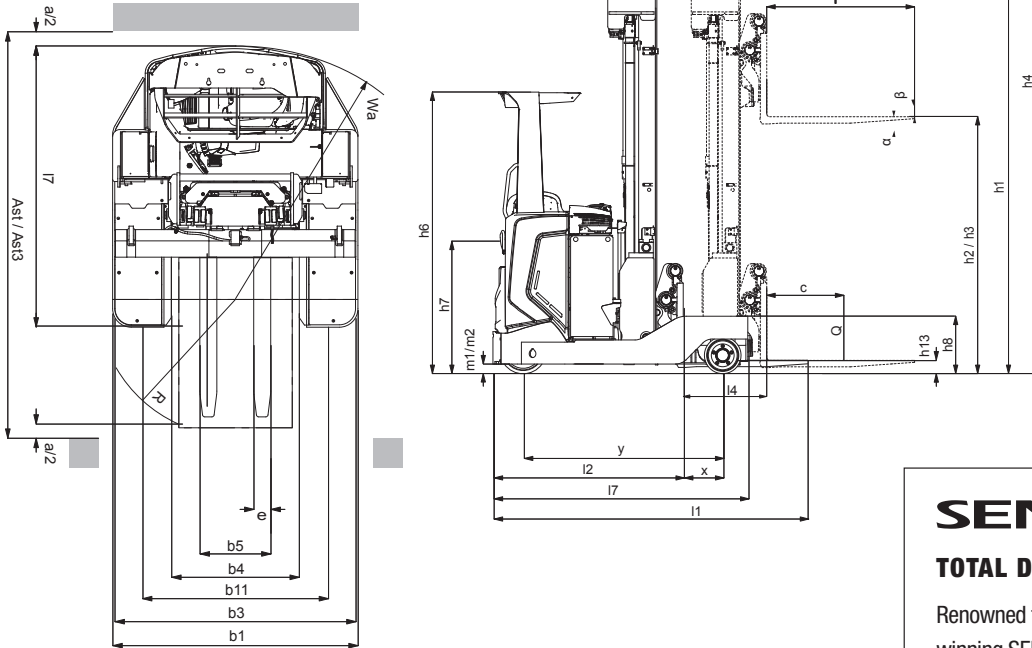

Six agile travel modes

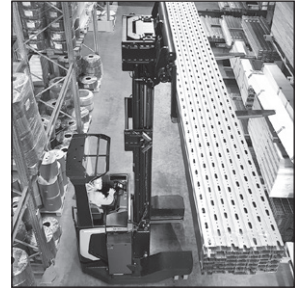

Precise handling of long loads



Fatigue-free operation

Six multiway driving modes <-> keypad buttons

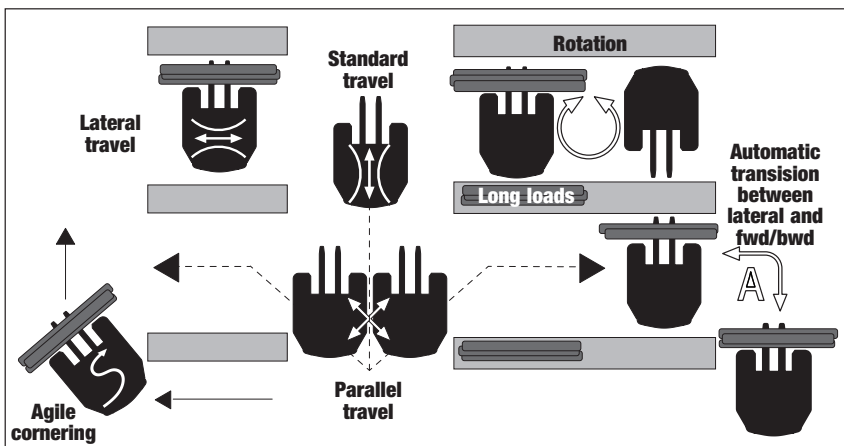

SENSIA

TOTAL DRIVER CONTROL

Renowned for their driveability, award-winning SENSIA reach trucks deliver class-leading performance in any workplace. The high performance SENSIA PRO mode allows experienced operators to maximise productivity, while new or temporary drivers can choose SENSIA's EcoLogic mode and extend shift life. Both benefit from SDS – Mitsubishi's Sensitive Drive System – that interprets their touch and further tailors truck performance to provide smooth operation. With a wealth of such smart design features, SENSIA reach trucks operators enjoy unparalleled comfort, unrivalled support ... and absolute control.

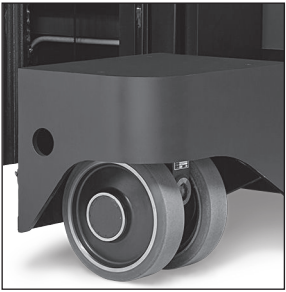

All-wheel steering and braking

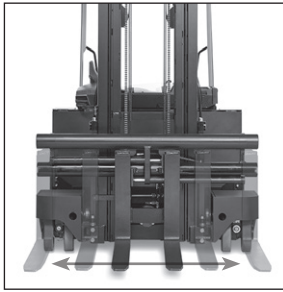

Wide spread/tilt fork positioner



Rapid TruckTool tailoring and diagnostics

Steering system

- **Unlimited 360-degree all-wheel steering** gives precise control with minimal effort
- **Progressive steering** enables easy manoeuvring at low speeds and effortless control when moving at speed

Brakes

- **High-efficiency regenerative braking** means effective control and reduced brake wear.
- **Hydraulic load wheel brakes** deliver agile performance.

Hydraulics

- **Powerful AC hydraulic pump motor** provides smooth lifting and lowering.

Electrical and control systems

- **AC power on all motors** delivers smooth performance, high torque and precise control - through the longest shifts.
- **High performance ZAPI motor drive controller** delivers robust and efficient traction control.
- **Temperature control** in drive and lift motors and controllers prevents damage from overheating.
- **Battery rollers** make changes quick, easy and safe.

Operator compartment and controls

- **Spacious and comfortable operator compartment**, with clear views and fast, accurate fork positioning increases productivity and reduces risks of driver fatigue - even on the longest shifts.

- **Easy-access compartment** with ergonomic hand bars, low non-slip step and entry provides safe and effortless entry and exit.

- **Folding steering wheel console** with adjustment for column length and angle, lifts fully upwards for easy access and ensures optimum position for each driver.

- **Multi-functional armrest with four-fingertip control** keeps control for reach, lift, tilt, fork positioning, direction and horn all at the driver's constant touch.

- **Multi-way-mode keypad control** is within driver's easy reach - for easy selection of its 6 travel modes.

- **Easy-to-understand display** communicates key information to driver including guidance, warnings and alarms - encouraging good practice.

- **EcoLogic and Professional modes (ECO/PRO) are quickly selectable by operator** for extended shift life or enhanced performance.

Options include

- **Choice of 2000kg and 2500kg capacities.**
- **Choice of masts up to 10.0m**
- **Choice of fork positioner widths** (1700mm or 2200mm)
- **BlueSpot pedestrian warning system** alerts co-workers to trucks operating nearby.
- **Working/drive lights** to improve visibility in dark environments
- **Choice of key switch or PIN code access.**
- **Load check scale** (+/- 50kg) helps driver to identify overweight loads.
- **Wide choice of seats, armrests and headrests** for maximum comfort and minimum fatigue.
- **Convenient USB Power socket** for phone charging or other 5V personal equipment.
- **Audio system and 3.5mm input jack** for MP3 player etc.
- **Quick, foot-operated battery-locking system**



when
reliability is everything...

Like any product bearing the Mitsubishi name, our materials handling equipment benefits from the huge resources and cutting-edge technology of one of the world's largest corporations. So when we promise you **quality, reliability and value for money**, you know it's a guarantee we have the power to deliver.

Every model in our comprehensive, award-winning range of forklift trucks and warehouse equipment is built to a high specification and is designed to keep on working for you... day after day... year after year... whatever the job... whatever the conditions.

To ensure your truck stays in constant productive action, we have a network of local dealers - hand-picked for their commitment to customer care... and backed up by the Mitsubishi Forklift Trucks organisation. No matter where you are, we have a dealer close by - ready and willing to meet your needs.

That friendly local service covers everything from identifying the perfect model and configuration for your application to providing competitive, flexible finance and maintenance packages, unbeatable warranties, long and short term hire, and highly responsive field service and repairs... as well as the industry's quickest and most reliable parts supply.

Only Mitsubishi can give you this combination of global engineering excellence and outstanding local support... only Mitsubishi offers you such a quality product at such an affordable price... and only Mitsubishi places reliability as high as you do in its priorities. Contact your local dealer now and see what Mitsubishi can do for you.

You can find your nearest dealer at www.mitforklift.com



WESM1830 (03/17)
© 2017 MCFE
Printed in The Netherlands

mitforklift@mcf.nl www.mitforklift.com

NOTE: Performance specifications may vary depending on standard manufacturing tolerances, vehicle condition, types of tyres, floor or surface conditions, applications or operating environment. Trucks may be shown with non-standard options. Specific performance requirements and locally available configurations should be discussed with your distributor of Mitsubishi forklift trucks. Mitsubishi follows a policy of continual product improvement. For this reason, some materials, options and specifications could change without notice.